

Forix™ - IP 2X
2 P+E French socket

Cat. No(s): 7 824 17/47

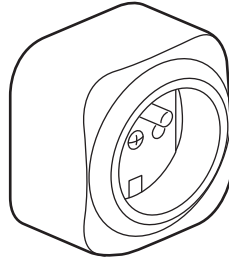

1. USE

General 16 A socket outlet with shutters.

2. RANGE

Finishes		Designation
White	Ivory	
7 824 17	7 824 47	2 P+E socket with shutters

3. OVERALL DIMENSIONS

■ 3.1 Socket

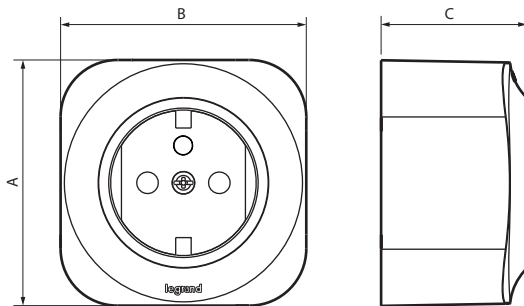

Cat. No.	A	B	C
7 824 17/47	65	65	38.5

■ 3.2 Base:

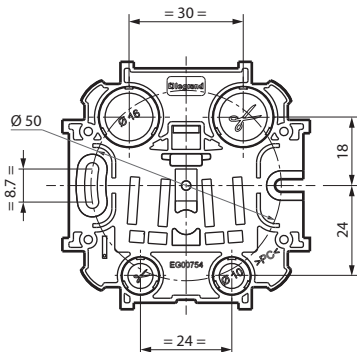

4. CONNECTION

Information for pre-cut:

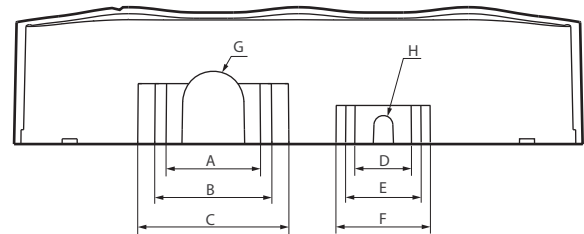

Cat. No.	Pre-cut sides (mm)			
	A	B	C	D
7 824 17/47	25 x 16	31 x 16	40 x 16	15 x 10
	2	-	-	2
	E	F	G	H
	20 x 10	25 x 10	Ø 16	Ø 5
	2	-	2	2

Terminal type: with screws
 Terminal capacity up to: 2 x 2.5 mm²
 Recommended screwdriver size: pozidrive No 2
 Recommended tightening torque: 0.8 Nm

5. TECHNICAL CHARACTERISTICS

■ 5.1 Mechanical characteristics

Protection against liquids: IP 21
 Impact tests: IK 04

■ 5.2 Material characteristics

Cover: PP
 Mechanism: PC

■ 5.3 Electrical characteristics

Voltage: 250 VAC
 Current: 16 A

■ 5.4 Climatic characteristics

Storage and use temperature: - 25° C to + 60° C

6. CLEANING

Surface cleaning with a cloth.

Do not use: acetone, tar remover, trichloroethylene.

Resistance to the following agents: Hexane (EN 60669-1), Methylated spirits, Soapy water, Diluted ammonia, Diluted pure bleached 10%, Glass cleaning substance, Pre-impregnated wipes.

Caution: A preliminary test should be carried out if other specific cleaning products are to be used.